

ONEU[®] ACTIVE EXTINGUISHING SYSTEM



Comprehensive protection that fits inside a 19" server rack

Clean, compact, and sustainable server protection

The OneU[®] active extinguishing system is a compact and independent unit uniquely designed to detect and extinguish fires in closed 19" cabinets.

The OneU's compactness is one-of-a-kind. With its height of only 1U (1.75") and width equal to a 19" rack, it provides complete and reliable fire protection without robbing space from IT components and equipment. Now you can protect against fires from shorts, overloads, overheating, and component failures in the smallest space possible.

The OneU is perfect for Server, Network or Telecommunication Cabinets as well as for Production Control Cabinets in industrial applications.



Features

The OneU is a sensitive smoke aspiration system with two permanently monitored fire detectors that continuously take air samples from within the cabinet. The OneU detects an incipient fire and operates in two states: On pre-alarm, power circuits can be switched off simultaneously with the alarm signal, isolating supporting electrical energy. On fire alarm, the extinguishing system is activated and Novec[™] 1230 extinguishing agent vaporizes at the nozzle and is distributed throughout the cabinet to rapidly extinguish the fire without leaving any agent residue.

The OneU display shows detailed alarm and fault information. Separate outputs are available to activate external audible or visual alarms.

The following components are contained in the 1.75" height of the OneU active extinguishing system:

- A sensitive smoke aspiration system
- An extinguishing agent container with agent monitoring and discharge nozzle
- Seven pounds of Novec[™] 1230 to protect up to 100 cubic feet cabinet volume
- A battery-buffered emergency power supply
- Evaluation and control systems
- Outputs for external alarm equipment and for external power shut downs
- Control panel with display, alarm, fault and status LEDs and operating keys

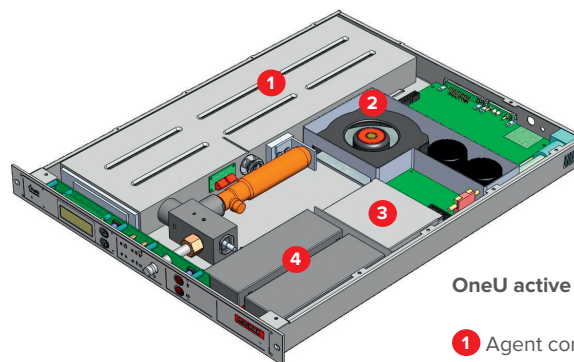
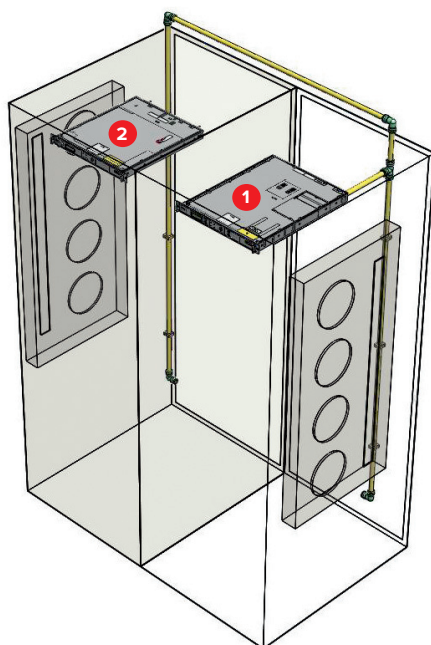

OneU active extinguishing system

1 OneU active extinguishing system monitors two cabinets with one sampling pipe, to activate 2 a separate OneU ED extinguishing device.

- 1 Agent container with release mechanism and discharge nozzles
- 2 Smoke aspiration system with two sensors
- 3 Power supply
- 4 Battery buffer

The OneU® Product Family

OneU, OneU DD and OneU ED models provide flexibility and expandability. The OneU DD smoke aspirating system has the same features as the OneU active extinguishing system without the Novec™ 1230 agent container. OneU DD can take air samples for smoke analysis from up to five cabinets. It can activate up to four OneU ED systems or any external extinguishing system. OneU ED extinguishing systems include a seven pound Novec™ 1230 agent container, activated to discharge either by a OneU active extinguishing system or the OneU DD smoke aspirating system. Various combinations are available to protect up to 5 combined cabinets.

OneU® Family Features			
	OneU ActiveExtinguishing System	OneU DD Smoke Aspirating System	OneU ED Extinguishing System
Height Fitting Dimension 1U (1.75")	•	•	•
Smoke Aspirating System	•	•	
Novec™ 1230 Agent Container	•		•
Power Supply and Battery Backup	•	•	•
Monitored Output Visual and Audible Alarm	•	•	•
Dry Contacts for Power Down Circuits	•	•	•
Display and Control Panel	•	•	
Ethernet - Network	•	•	•
*Power Supply through OneU Active Extinguishing System or OneU DD Smoke Aspirating System			

The perfect cabinet fire protection solution:

- Highly sensitive smoke detection and fire extinguishing without residues or harm to sensitive electrical equipment
- Space saving installation without feature, quality or reliability limitations
- All OneU family products are VdS approved

The OneU Active Suppression System employs safe and environmentally-friendly clean agent Novec™ 1230 from 3M™. This highly effective fire suppressant has low toxicity; an atmospheric lifetime of 5 days; zero ozone depletion; and significantly lower global warming potential than other agents. Novec™ 1230 will not damage electronics and leaves no residue behind, which dramatically reduces clean-up and minimizes downtime of critical assets.



Width 19" (483mm) / Height 1.73" (44mm) / 1U

discover...

MINIMAX FIRE PRODUCTS

For over 100 years, Minimax has delivered innovative solutions for the most demanding fire protection challenges around the world. Minimax Fire Products brings this capability to the North American market. We are part of the Minimax Viking Group, a leader in fire protection with over \$1.1 billion in sales and 6,000 employees. Our expertise in gas based fire detection and protection systems is supported by Viking SupplyNet's nationwide distribution and fabrication network, ensuring that you receive the best in system design and product availability from a single source.

Our Minimax research center in Bad Oldesloe, Germany works closely with test and standardization authorities to develop solutions often used as the basis for fire protection regulations and approvals. You can trust Minimax Fire Products to deliver the most reliable and cost-effective fire protection.



MINIMAX FIRE PRODUCTS

Phone 888.882.0191
 Fax 480.553.5701
 sales@minimaxfp.com
 www.minimaxfp.com

© 2014 Minimax USA LLC. All rights reserved.
 MX OneU 5/2014